



# Protector® Downdraft Powder Stations

## Features & Benefits

Protector Downdraft Powder Station keeps users safe by containing powders during fingerprint processing. It allows unrestricted operator movement and accommodates oversized evidence. Two or more stations

may be placed side-by-side to achieve an unlimited number of width combinations. An optional Transition Connector mounts between two stations for a secure fit and continuous work surface.

**HEPA filter**, 99.99% efficient on particles 0.3 micron, traps airborne particulates and powders as air is exhausted from the station's interior to the room. A prefilter protects the HEPA filter.

**Available in 2' and 3' widths; unlimited widths possible.** With one or more optional Transition Connectors, multiple stations may be linked together to increase the overall working width.

**Shelf** holds fingerprint powder, brushes and other small utensils and supplies.

**Red, filter system alarm light** illuminates to alert the operator to low airflow conditions that may indicate a loaded prefilter or HEPA filter.

**Fan switch** activates the blower.



**Durable powder-coated steel housing.**

**Flow-Zone™ perforations** in the work surface are designed to maximize containment of airborne fine powder. Airflow is directed downward through the hole pattern in the work surface.

**Type 304 stainless steel work surface** may be lifted up to access the pan beneath it. The pan catches powder and is removable for cleaning.

**Low-profile design** fits under existing cabinetry.

**Portable.** The work surface and pan may be easily detached without tools to allow the Station to be transported to remote locations such as crime scenes.

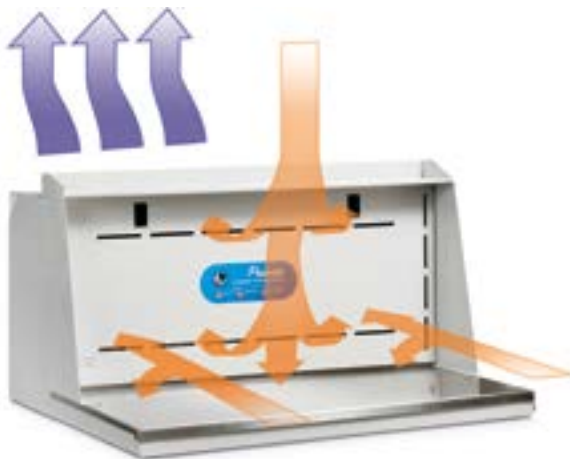

**Quiet built-in blower** pulls room air down through the work surface and horizontally through the back wall before discharging filtered air out the top rear of the enclosure. This dual zone approach optimizes containment. The motorized, backward curved fan is quiet and energy efficient.

**Energy savings.** Since air is recirculated, expensive heated or cooled air is not exhausted from the building.

**CAUTION:** Protector Downdraft Station does not provide protection from biohazardous aerosols or gaseous contaminants. Contact Labconco for information on biosafety cabinets and fume hoods if your application involves these contaminants.

□ Room Air   □ Contaminated Air   □ HEPA-filtered Air





# Protector® Downdraft Powder Stations

## Specifications, Ordering Information & Dimensional Data

### SPECIFICATIONS

- Open-sided, open-top design
- Powder-coated steel housing and shelf
- Type 304 stainless steel work surface with Flow-Zone™ perforations
- Removable powder catch pan
- Built-in blower with motorized, backward curved fan
- Fan switch
- Red, filter system alarm light to alert operator to low airflow conditions
- Exhaust prefilter of pleated paper with MERV 8 rating
- Exhaust HEPA filter, 99.99% efficient on particles 0.3 micron
- ETL listed (Models 3410000 and 3410001)
- CE conformity marking (Models 3410020, 3410021, 3410022, 3410023, 3410024 and 3410025)
- 6' (15 cm) power cord with plug

### REQUIRED ACCESSORY

- Supporting base. See back page.

 Exclusive feature



Protector Downdraft Powder Station 3410000 is shown on Variable Height Bench 8075000.

### ORDERING INFORMATION

Catalog #	Nominal Width	Electrical Requirements	Plug Type	Shipping Weight
3410000	2 Feet	115V, 60 Hz, 1A	115V, 13A	65 lbs. (29 kg)
3410001	3 Feet	115V, 60 Hz, 1A	115V, 13A	87 lbs. (39 kg)
3410020*	2 Feet	230V, 50/60 Hz, 1A	British (UK)	87 lbs. (39 kg)
3410021*	3 Feet	230V, 50/60 Hz, 1A	British (UK)	87 lbs. (39 kg)
3410022*	2 Feet	230V, 50/60 Hz, 1A	Schuko	65 lbs. (29 kg)
3410023*	3 Feet	230V, 50/60 Hz, 1A	Schuko	87 lbs. (39 kg)
3410024*	2 Feet	230V, 50/60 Hz, 1A	China/Australia	65 lbs. (29 kg)
3410025*	3 Feet	230V, 50/60 Hz, 1A	China/Australia	87 lbs. (39 kg)

\*International electrical configuration

### PLUG CONFIGURATIONS

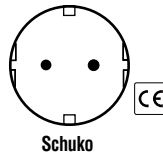
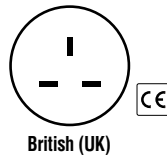

### DIMENSIONAL DATA

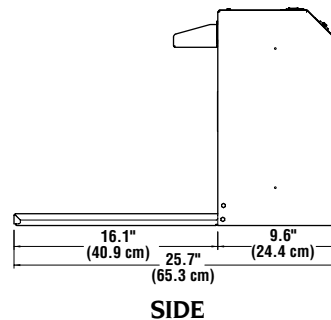
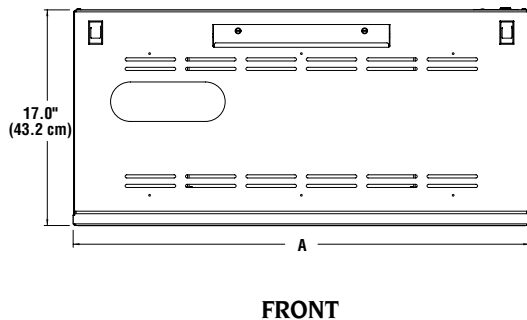

Catalog #	Nominal Width	A
3410000	2 Feet	24.0" (61.0 cm)
3410001	3 Feet	36.0" (91.4 cm)
3410020	2 Feet	24.0" (61.0 cm)
3410021	3 Feet	36.0" (91.4 cm)
3410022	2 Feet	24.0" (61.0 cm)
3410023	3 Feet	36.0" (91.4 cm)
3410024	2 Feet	24.0" (61.0 cm)
3410025	3 Feet	36.0" (91.4 cm)



# Protector® Downdraft Powder Stations

## Accessories

### ACCESSORIES

**3768903 Replacement Prefilter.** Pleated paper. MERV 8 rating. Shipping weight 1 lb. (0.5 kg).

**6938100 Replacement HEPA Filter.** 99.99% efficient on particles 0.3 micron. Shipping weight 9 lbs. (4.1 kg)

**3413300 Transition Connector.** Powder-coated steel bracket and fasteners connect two stations together, extending the width of the work surface area and creating a continuous work surface. Shipping weight 15 lbs. (7 kg)

**8075000 Variable Height Bench.** Powder-coated steel auxiliary bench has four adjustable heights from 29.6" to 37.4" (75.1 to 94.9 cm). Work surface is fiberboard with high pressure melamine laminate. 5" diameter (13 cm), non-marking polyurethane casters with toe locks provide mobility. Work surface dimensions are 38.0" x 28.0" x 1.1" thick (96.5 cm x 71.1 cm x 29 mm). Supports loads up to 540 pounds (245 kg). Lifetime guarantee. Shipping weight 105 lbs. (48 kg).



Variable Height Bench 8075000

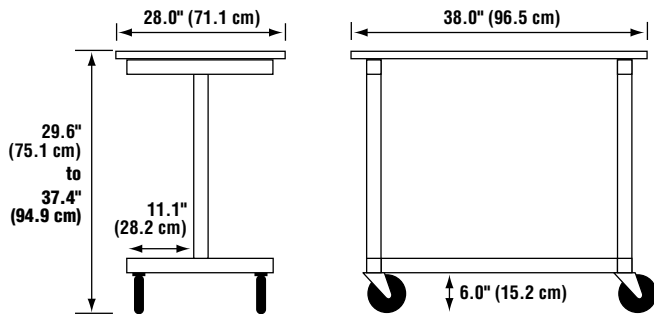

Mobile Equipment Table 3819100

**Mobile Equipment Tables.** Heavy duty table provides auxiliary bench space and may be transported from lab to lab. Base is constructed of 1.75" tubular steel with powder coating. Telescoping legs adjust to eight height positions in 1" increments from 28.75" to 35.75" (73.0 to 90.8 cm). 5" diameter (13 cm), non-marking polyurethane casters with toe locks have bearings for quiet operation. Work surface is seamless solid epoxy, 1.25" thick (32 mm) x 30.0" deep (76.2 cm). Supports loads up to 800 pounds (363 kg).

Nominal Width	Catalog Number	Overall Width x Depth	Shipping Weight
4 feet	<b>3819100</b>	48.0" x 30.0" (121.9 cm x 76.2 cm)	250 lbs. (113 kg)
5 feet	<b>3819101</b>	60.0" x 30.0" (152.4 cm x 76.2 cm)	300 lbs. (136 kg)
6 feet	<b>3819102</b>	72.0" x 30.0" (182.9 cm x 76.2 cm)	350 lbs. (159 kg)



### Labconco Corporation

8811 Prospect Avenue • Kansas City, Missouri 64132-2696  
816-333-8811 or 800-821-5525 • labconco.com

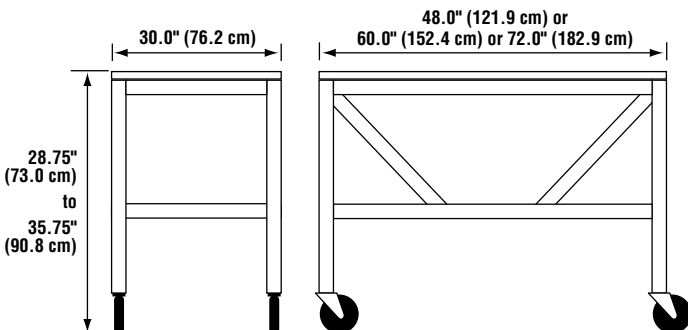

© 2018 by Labconco Corporation.  
Product design subject to change without notice.  
Printed in the U.S.A.